



Year 10
Revision Guide
Christmas Examinations
2023

Name:	
Form Class :	
Parent Signature	

About this guide

At Cullybackey College our motto is 'creating opportunities for success'. Young people today are measured on their performances and grades across a host of subjects, so it is important that we help to support our students to achieve their very best.

We want our students to get into the good habits of working hard and preparing thoroughly for exams from an early age. We want them to experiment with different revision techniques and we want them to realise the importance that revision plays in making sure that they achieve the result that they are capable of and the result that they can be proud of.

This short guide gives a little bit of help and support as you plan for the exams that will be taking place between Mon 27th November to Thurs 30th November 2023.

Don't forget that the grades you achieve are a direct result of the amount of effort, time and work that you put in.

All the very best for your exams,

Mr T Manson

Vice Principal



Getting ready for the exams . . .

Exams are not meant to be easy – they are designed to be something that will test your knowledge and understanding across the different subjects that you study.

Here are a few tips that might help

1. **Study environment:** try to find a quiet, peaceful place where you can work. Turn off the TV, the music and your computers and digital devices
2. **Know what you are meant to learn:** make sure that you know what you have been studying, that all missing notes have been copied up and that you know what might be coming up in the exam
3. **Take notes of your notes:** it is not enough to just sit with your book open to read – you need to rework your notes and try to remember the key points – why not . . .
 - a. reduce your notes down to sentences or key words
 - b. colour code your revision with highlighters
 - c. create a mindmap
 - d. turn your notes into pictures
4. **Memorise:** you need to get your subject notes into your head!
 - Use your hand to cover and check what you can remember
 - Use Post its – put a question on one side and the answer on the other side
 - Make posters for your bedroom with the key things you need to remember
 - Test yourself – ask a friend or parent to ask you questions.
5. **During the exam:** Close your eyes, take a deep breath . . .
 - Read every question carefully. Underline the key words in the question.
 - Show what you know!
6. **Stay fit and healthy:** During exams make sure that you drink enough

Art



Year 10 – Observational Drawing

As you know you will be given the task of completing a split portrait for your exam. You will have practiced this in class with your teacher.

In order to prepare for your exam, you should:

- Practice the split portrait task both in class and at home. You will be working on A3 size paper in your exam, remember this is twice the size of your normal A4 paper.
- Follow the instructions below to ensure you are not missing any vital elements of the drawing.
 1. Neatly fold the portrait image in half and cut it down the middle. Tip – if you are right handed stick down the left side of the face. If you are left handed stick down the right side of the face. The other half of the portrait can be thrown away.
 2. You will need a ruler, pencil, rubber and sharpener to complete the portrait.
 3. Use your ruler to mark measurements on the blank side of the page. Mark out key points which will serve as a guide. For example, how far from the centre line are the ears, jaw, forehead etc. You will have practised this in class, take your time when measuring key points as this will ensure your portrait is in proportion.
 4. When you have measured out the key points you will effectively be able to ‘join the dots’ to create the outline. If your measurements are correct you will have a perfect outline! Repeat the same process of measuring key points to add in the facial features.
 5. Now that the outline is complete you are ready to add tone, I recommend adding the darkest areas first then working gradually through the lighter tones.
 6. You will receive marks for including the full tonal range. You should also remember to leave highlights.
 7. When you have finished the drawing check areas of tone are well blended!



English



The Year 10 Christmas exam is a Reading paper.

- Practise non-fiction comprehension activities

Revise:

- PAF (Purpose, Audience and Form)
- Language techniques / devices such as: simile, metaphor, alliteration, superlative, rule of 3/triple, imperative...
- Parts of speech: adverb, adjective, verb and noun
- Varied sentence structure
- How to use the PEE/WPTEAA structure effectively when explaining or analysing a writer's work
- A range of punctuation
- Use evidence effectively to your support answers

REMEMBER TO ANSWER ALL QUESTIONS IN FULL SENTENCES

REMEMBER TO READ THE TEXT CAREFULLY BEFORE YOU BEGIN

French

Qu'est-ce que tu penses de tes matières? (What do you think of your subjects?)
 Quelle est ta matière préférée ? (What is your favourite subject ?)

J'aime (I like) J'aime beaucoup (I really like) J'adore (I love) Je n'aime pas (I don't like) Je ne supporte pas (I can not stand) Je déteste (I hate) Je préfère (I prefer)	le français (French) le dessin (Art) le théâtre (Drama) la géographie (Geography) la musique (Music) la technologie (DT) l'anglais (English) l'espagnol (Spanish) l'informatique (ICT) l'histoire (History) l'EPS (l'éducation physique et sportive) (PE) l'instruction religieuse (RE) les mathématiques (Maths) les sciences (Science) les arts ménagers (HE)	parce que (because) car (for)	c'est (it's)	passionnant (exciting) amusant (fun) bon (good) fantastique (fantastic) créatif (creative) relaxant (relaxing) actif (active) intéressant (interesting) fascinant (fascinating) marrant (funny) utile (useful) facile (easy) plus facile que...(easier than) ennuyeux (boring) trop dur (too hard) difficile (difficult) horrible (horrible) inutile (useless) nul (bad)
			je suis (I am)	nul(le) en maths bad (at maths) bon(ne) en espagnol good (at Spanish)

Le lundi (on Monday) Le mardi (on Tuesday) Le mercredi (on Wednesday) Le jeudi (on Thursday) Le vendredi (on Friday)	à (at)	neuf heures et quart 9.15 dix heures moins dix 9.50 onze heures moins vingt 10.40 onze heures et quart 11.15 midi moins dix 11.50 une heure cinq 1.05 deux heures moins vingt 1.40 deux heures et quart 2.15 trois heures moins dix 2.50	j'ai (I have)	le français (French) l'anglais (English) l'histoire (History) le dessin (Art) les sciences (Science) la musique (Music) le théâtre (Drama)
--	--------	--	---------------	--

Tu aimes tes profs?
 (Do you like your teachers?)

Je pense que (I think that) À mon avis (In my opinion)	ma (f)/ mon (m) prof (my teacher)	de maths de géo de français d'anglais d'espagnol d'histoire d'informatique	est (is)	sympa (nice) trop sévère (too strict) enthousiaste (enthusiastic) positif/positive (positive) travailleur/travailleuse (hardworking) gentil(le) (kind) marrant(e) (funny) barbant(e) (boring) bien organisé (well organised)
---	---	--	----------	--

Je (I)	me réveille (wake up) me lève (get up) me lave (get washed) me douche (shower) me repose (rest) me couche (go to bed) m'habille (get dressed)	à (at) vers (around)	cinq heures 5.00 six heures 6.00 sept heures 7.00 huit heures cinq 8.05 neuf heures dix 9.10 dix heures et quart 10.15 onze heures vingt 11.20 deux heures vingt-cinq 2.25 trois heures et demi 3.30 quatre heures moins vingt-cinq 3.35 quatre heures moins vingt 3.40 quatre heures moins le quart 3.45 quatre heures moins dix 3.50 quatre heures moins cinq 3.55 midi 12pm minuit 12am	puis (then) après (after) finalement (finally) et (and)
quitte la maison (leave the house) prends le petit déjeuner (have breakfast) vais au collège (go to school) déjeune (have lunch) dîne (have dinner) rentre à la maison (go home) regarde la télé (watch TV) fais mes devoirs (do my homework)				

J'ai neuf cours par jour (I have 9 lessons per day)

Les cours (lessons)	commencent (start) finissent (end)	à (at)	neuf heures et quart 9.15 trois heures vingt-cinq 3.25
La récréation (break time)	est (is)		dix heures vingt-cinq 10.25
La pause déjeuner (lunchtime)			midi vingt-cinq 12.25

Mon collège s'appelle Cullybackey College (My school is called Cullybackey College)

Il est situé à Cullybackey, près de Ballymena en Irlande du nord.
(It is situated in Cullybackey, near Ballymena in Northern Ireland.)

Mon collège est (My school is)	assez (quite) un peu (a bit) très (very)	grand/petit (big/small) moderne (modern) lumineux (bright) vieux (old)
Le bâtiment est (The building is)		
Au rez-de-chaussée (on the ground floor) Au premier étage (on the first floor) Au deuxième étage (on the second floor)	il y a (there is)	les salles de classe (the classrooms) une salle de sport (a sports hall) un terrain de sport (a sports pitch) une bibliothèque (a library) une cantine (a canteen) les laboratoires (the labs) la cour (the playground)
À mon avis... (In my opinion...)	Il n'y a pas de (there is no)	piscine (pool) gymnase (gym)
Je pense que... (I think that...)	mon collège est (my school is)	très bien (very good) assez bien (quite good) trop strict (too strict) amusant (fun) barbant (boring)

Geography

Topic: Map Work

Students should be able to use the following skills on an Ordnance Survey map:

State direction (4 and 8-point compass)

Identify features using symbols and the map key

Identify the height of land using an Ordnance Survey map

Using four figure grid references

Using six figure grid references to locate features

Measuring the straight line distance between two places using 1:50,000 scale

Topic: Rivers

Understand the following topics:

Weathering

Types of Weathering

Erosion, Transportation and Deposition

Features of the drainage basin.

Waterfalls and Gorges.



History

Topics to be covered on the examination include: The 20th Century and WW1.

20TH CENTURY

20th Century

- Historians state that the 20th century was the “bloodiest century” yet it was the century where the greatest changes took place.
- What events happened during the 20th century?
- Was the 20th Century a good or a bad century?



World War One

- What were the Long term causes of World War One? (MAIN)
- Explain why is meant by the term militarism, alliances, imperialism and nationalism.
- What countries made up the Triple Alliance?
- What countries made up the Triple Entente?
- The Trigger Event – The assassination of Franz Ferdinand. What happened in Sarajevo?
- What did WW1 start in 1914?
- The Schlieffen Plan.
- Trench Warfare – How and why did Trench Warfare start?
- What does a Trench look like?
- What was life like in a trench?
- What problems did soldiers in the trenches face?

In the examination you will see lots of sources – ensure to use the sources when answering questions.

Home Economics

1. Know all about Iron

Function in the body.

Haem and Non-haem iron and good sources of each.

How much iron is needed daily by teenagers?

Which vitamin helps absorb iron?

People who may be deficient in iron and why.

What are fortified foods.

Anaemia- causes and symptoms.



2. Know the 8 Healthy Eating Guidelines

3. The Eatwell guide

Names for each group, portions from each and foods contained in each of the groups.

Practical ways to eat more fruit and veg in the diet.

Practical ways to eat more fibre in the diet.

Practical ways to eat less salt.

Practical ways to eat less sugar.

Practical ways to eat less saturated fat.

3. Know diseases related to

Too much salt (e.g. high blood pressure and strokes).

Too much fat (e.g. obesity and coronary heart disease).

Too much sugar (e.g. obesity, diabetes and tooth decay).

Not enough fibre (e.g. constipation, diverticular disease and bowel cancer).

4. Recipe Adaptation

Know how to adapt a recipe – learn examples in files.

Maths

Pythagoras' Theorem

- Understand, use and apply in 2D
- Find the midpoint of two co-ordinates, or the midpoint of a line
- Find the length of a line given in co-ordinates

Ratio

- Use the term ratio and ratio notation
- Simplify ratios
- Share a quantity in a given ratio
- Use ratio in real-life examples: including maps and recipes

Angles, Triangles and Parallel Lines

- Name the types of triangles using their sides and angles
- Use letters to give the name of angles
- Calculate interior and exterior angles
- Calculate the missing angles in triangles and quadrilaterals
- Recognise, label and draw parallel lines
- Name angles made by intersecting lines
- Construct triangles with compass/protractor and ruler

Co-ordinates and Straight Line Graphs

- Plotting and identifying points in all four quadrants
- Locate position (including maps, angles and turns)
- Generate co-ordinates for a line
- Explore linear functions and make tables of linear function
- Plot straight line graphs
- Find the gradient of a straight line graph



Music



Your Music Christmas Exam will include questions on the following topics. The page numbers in brackets will tell you some of the pages you can use in your booklet to help you revise.

- 1. Pop Music:** You need to know:
 - a. The 2 definitions of pop. (page 7)
 - b. Some different pop styles. (page 7)
 - c. The top singer/band in each decade. (page 9)
 - d. Things other than the music that will help a song/singer be successful. (page 20)
 - e. The four instruments most commonly found in a rock/pop/worship band. (page 17)
 - f. What most pop songs are about.
- 2. Note Values:** Know the names, how to draw and the number of beats for the following notes: Semibreve, minim, crotchet, quaver, semiquaver, 2 quavers together and 4 semiquavers together, dotted notes and tied notes. (Page 27-29)
- 3. Notes on the Treble Clef Staff:** Know a rhyme for notes drawn on the lines, know what the space notes spell, and be able to read and draw notes in the lines and spaces and how to read notes above and below the lines and spaces. (Page 27)
- 4. The Music Keyboard:** Know how to read the white keys and black keys on a keyboard. (pages 32 & 33)
- 5. Chords:** You need to know how to pick the notes of a chord, how to find the notes on a keyboard and how to draw the notes of a chord. (pages 34-38)

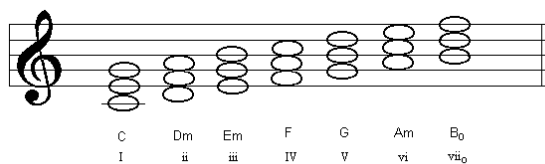

RE

Topic 1 – Events Leading to the death of Jesus

- Holy Week
- The road to Calvary
- The crucifixion, death and burial of Jesus
- Why is the crucifixion important for Christians today?



Topic 2 – Resurrection and Ascension of Jesus

- The women at the tomb
- Why is the resurrection important for Christians today?
- Ascension

Topic 3 – The coming of the Holy Spirit

- The Pentecost Story

Wow Words



Science

1. Periodic Table

- Elements, compounds and mixtures
- Periodic table structure
- Alkali metals
- Atomic structure
- Electronic structure
- Covalent & ionic bonding
- Separations
- Acids and Alkalis



Technology & Design

Your year 10 Technology Exam will be based on the following topics:



Health & Safety

- Know the Health & Safety rules you must obey when completing practical work in the workshop.
- The correct PPE that should be worn when using machinery.
- What HASAWA stands for and its aim.
- Be able to identify employer and employee responsibilities.
- The types of accidents that could occur if rules aren't applied.



Tools & Equipment

- Able to draw and label the parts of a Tenon Saw.
- Discuss how to use a Pillar Drill and safely.
- What a Jig is and why they are used in a manufacturing process.

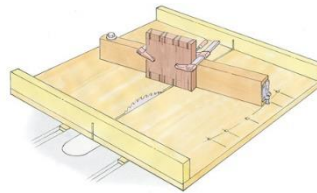

Materials

- Understanding of Woods.
- Be able to identify the difference between a hardwood, softwood, and manufactured board.
- Identify the different type of wood joints.: Housing Joint

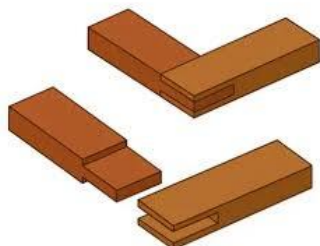

Half-Lap Joint
Mortise & Tenon Joint
Bridle Joint

Design Task

- Use of drawing skills to create a specific Isometric drawing.

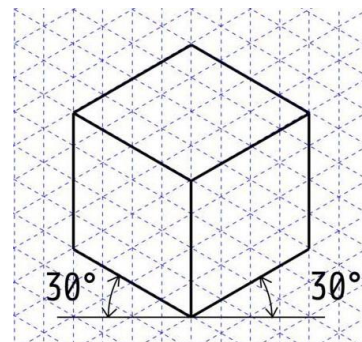

You will receive a further revision guide in class to help with exam revision.

Spanish

Key Topic: "Donde Vivo" – Where I live Booklet

<u>Learning Objective</u>	<u>I am:</u>	<u>YES?</u> <u>NO?</u>
1	Able to say where you live and describe it using a range of adjectives	
2	Able to say what is in your town/village and what you would like to have	
3	Able to describe your house	
4	Able to describe where you would like to live in the future	
5	Able to ask for/give directions	

Revision Materials:

Revision materials and spare booklets are available to access via Google Classroom. There you will also find links to Quizlet Vocabulary Sets for each learning objective.



Year 10 Exam Timetable

From Mon 27th November to Thurs 30th November 2023

Y10	1 08:55 – 10.00	10.15- 10.30	2 10:30 – 11.30	11.30 – 12.00	12.00– 12.30	3 12.30 – 13:30	13:30 – 14:00	4 14:00 – 15:00
Mon	Music ½ hour	Break	Maths 1 hour	Revision	Lunch	Art 1 hour	Revision	RE 45 mins
Tues	Technology 45 mins	Break	English 45 mins	Revision	Lunch	Science 1 hour	Revision	Spanish ½ hour
Wed	French ½ hour	Break	Geography 45 mins	Revision	Lunch	History 1 hour	Revision	HE 45 mins
Thurs	Exceptional Closure							

My Revision Timetable

Week beginning Mon 6th November 2023

Time	Monday 6 Nov	Tuesday 7 Nov	Wednesday 8 Nov	Thursday 9 Nov	Friday 10 Nov	Saturday 11 Nov	Sunday 12 Nov
9 – 10am							
10 – 11am							
11 – 12am							
12 – 1pm							
1 – 2pm							
2 – 3pm							
3 – 4pm							
4 – 5 pm							
5 – 6pm							
6 – 7 pm							
7 – 8pm							
8 – 9pm							
9 – 10pm							

My Revision Timetable

Week beginning Mon 13th November 2023

Time	Monday 13 Nov	Tuesday 14 Nov	Wednesday 15 Nov	Thursday 16 Nov	Friday 17 Nov	Saturday 18 Nov	Sunday 19 Nov
9 – 10am							
10 – 11am							
11 – 12am							
12 – 1pm							
1 – 2pm							
2 – 3pm							
3 – 4pm							
4 – 5 pm							
5 – 6pm							
6 – 7 pm							
7 – 8pm							
8 – 9pm							
9 – 10pm							

My Revision Timetable

Week beginning Mon 20th November 2023

Time	Monday 20 Nov	Tuesday 21 Nov	Wednesday 22 Nov	Thursday 23 Nov	Friday 24 Nov	Saturday 25 Nov	Sunday 26 Nov
9 – 10am							
10 – 11am							
11 – 12am							
12 – 1pm							
1 – 2pm							
2 – 3pm							
3 – 4pm							
4 – 5 pm							
5 – 6pm							
6 – 7 pm							
7 – 8pm							
8 – 9pm							
9 – 10pm							

